

DE-BARKER

C84

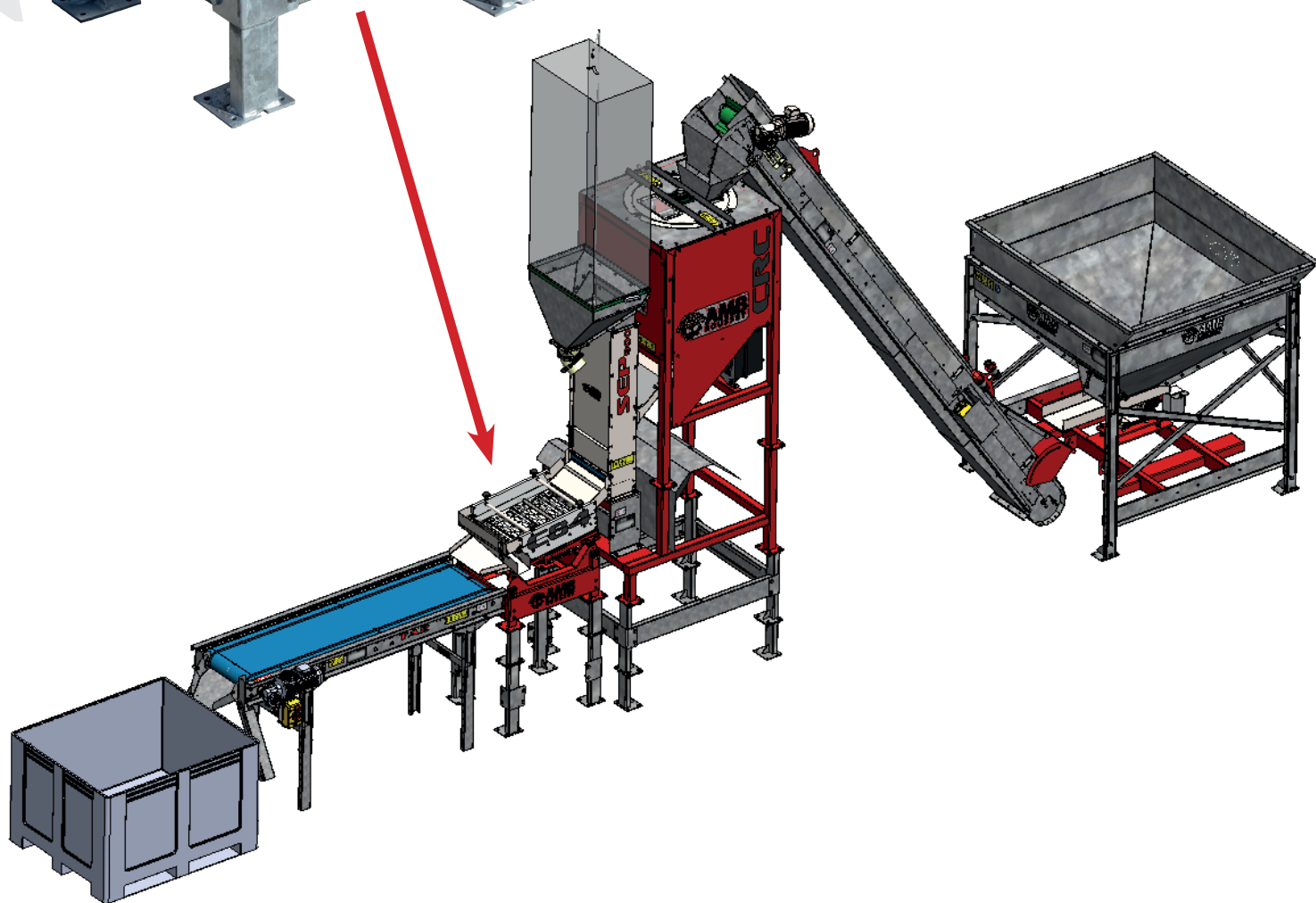

Manufacturer of solutions for the harvest and work of the fruits 

A M B Rousset
impasse du Tilleul
38470 BEAULIEU - France



AMB
ROUSSET

Tél : +33 (0) 4 76 36 73 73
Fax : +33 (0) 4 76 36 70 82
E-mail : export@ambrousset.com
www.amb-rousset.com

General characteristics

Flat vibrating deburrer

This machine works with all types of nuts.

Enables management of high product flow rates with autonomous unclogging.

Technical specifications

Operation	Flat vibrating debulker with stacked stainless steel grids, separates almonds and unbroken fruit into 2 or 3 categories.
Flow rate	800 kg/h of nuts
Motorization	0.17 kW (380 V)
Chassis	Steel painted with food-grade varnish / product contact stainless steel or HDPE
Technical specifications	separation into 2 sizes using a stainless steel grid / unclogging using a cleaning ball
Options	Separation with 1 additional gauge (3 in total)
Safety	CE standards
Dimensions	Length: 960 mm / Width: 863 mm / Height: 713 mm
Weight	96 kg

