

# OPTICAL SORTER BY FALL **GSXZ**

## THE REAL SORTING SOLUTION

Specifically for KERNELS



Watch the video!

**Manufacturer of solutions for the harvest and work of the fruits** 

**A M B Rousset**  
impasse du Tilleul  
38470 BEAULIEU - France





Tél : +33 (0) 4 76 36 73 73  
Fax : +33 (0) 4 76 36 70 82  
E-mail : [export@ambrousset.com](mailto:export@ambrousset.com)  
[www.amb-rousset.com](http://www.amb-rousset.com)

# OPTICAL SORTER BY FALL **GSXZ**

## The **GSXZ** sorter adapts to all situations.

In the walnut world it allows to sort in an efficient way the following products :

ACCEPTED	
<b>KERNELS</b>	
	
REJECTED	
<b>SHELLS MEMBRANES</b>	<b>COLORS</b>
	

### PRECISION :

- Ejection nozzles every 5mm.
- Viewing defects from 0.02mm.
- Simultaneous vision above and below the product.

### PERFORMANCE :

- Viewing the product 9 000 times per second.
- Until 1400 ejections par second.

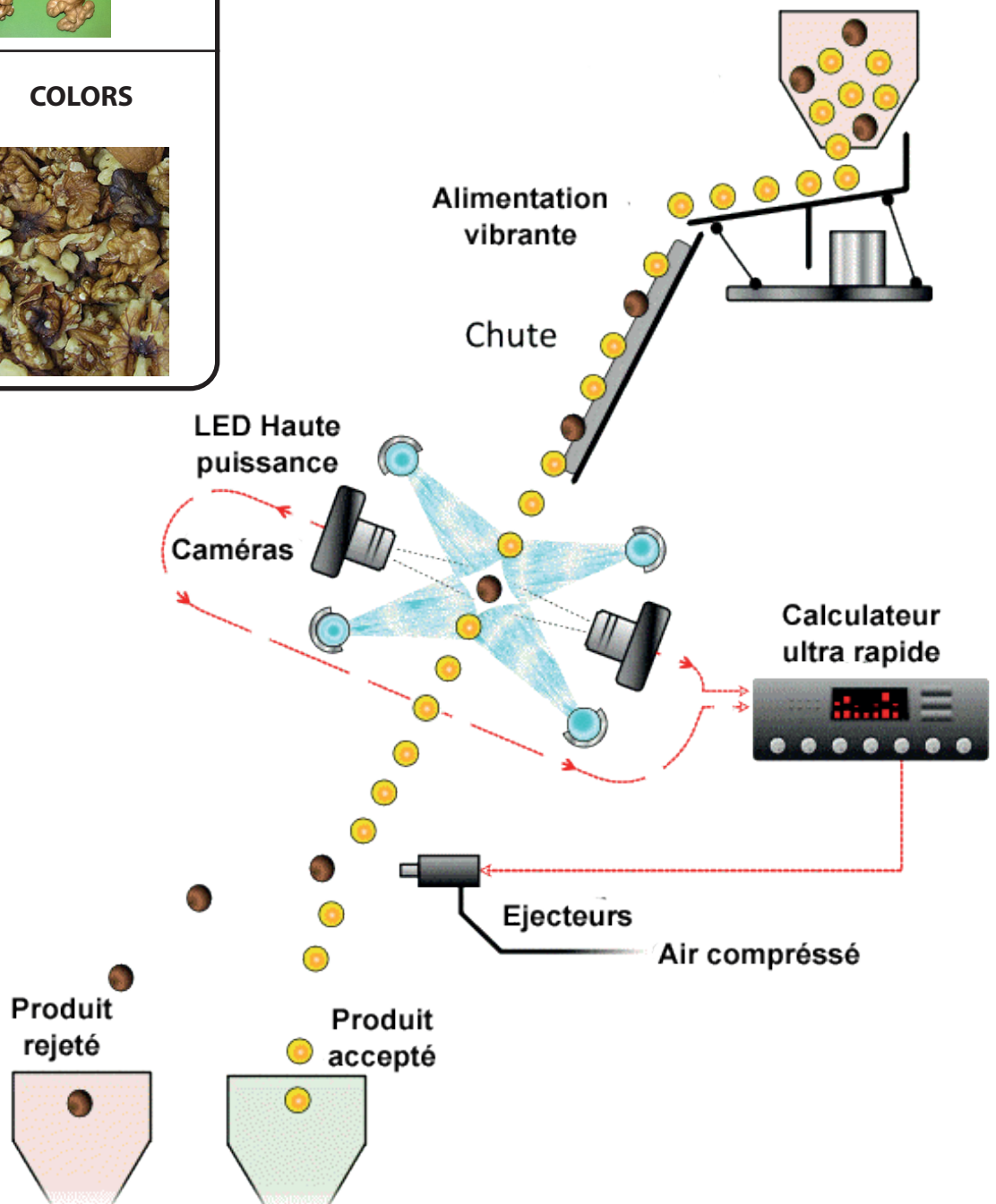

## INTERFACE

- Touch screen IP6X
- Easy (user-friendly) Interface
- Change settings in real time
- Fast and easy to understand
- French/English/Italian/Spanish
- Saving settings in batches (recipes)

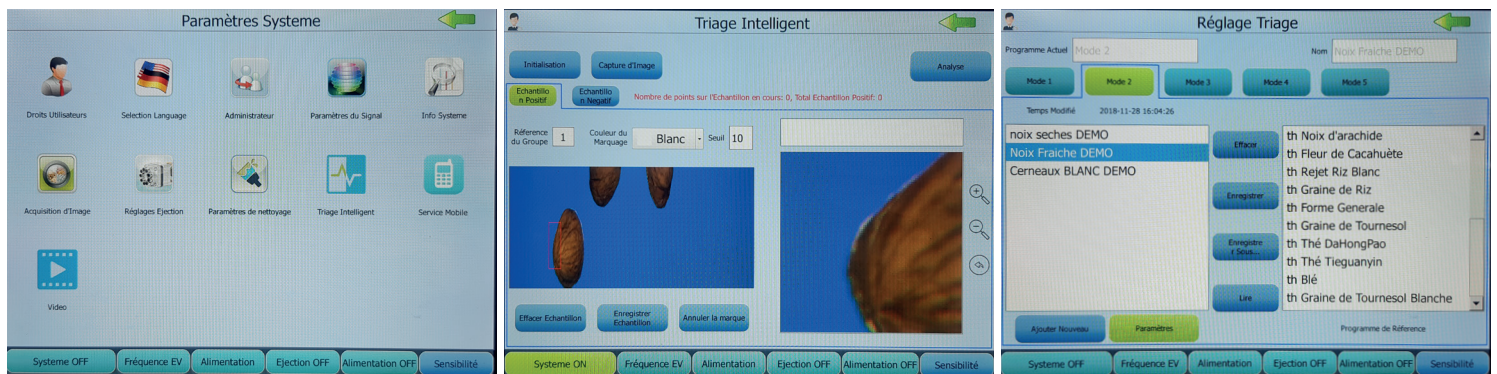

## RELIABILITY

- LED lighting is guaranteed for 100,000 hours.
- Industrial solenoid valves guaranteed for 5 000 000 000 cycles.
- Industrial cameras perfectly protected from dust and humidity.
- Few mechanical parts.
- Fast diagnosis in case of failure.
- Remote maintenance.
- Ejection nozzles 100% removable.
- Automatic camera and carpet cleaning.
- Machine in IP6X therefore clean with clear water or compressed air (blower).



## INTEGRATION

- Single feeding hopper on a vibrating channel.
- Food grade belt and 100% stainless steel chassis
- Tapis d'évacuation produit configurable (droite ou gauche) inclus.
- Goulotte spécifique de reception (option).
- Set-up on wheels or pallet chassis to be movable (Optional)
- 100% remote controllable. By local network wifi or ethernet



## CONFIGURATIONS:

- Depending on the product(s) to be sorted and the defects to be removed, different camera configurations are available :

**COLOR CAMERAS :** Advanced technology that offers the best sorting quality.

(E.g. kernels color sorting, without managing shells & membranes)

**INFRARED CAMERAS :** Advanced technology to bring out certain materials to better eject them (e.g. pebbles, wood, shells, metal, etc...).

These cameras are essential if you want a perfect result on products very complicated to sort.

It comes in several configurations to fit your workload:

**1 - 2 - 4 - 5 - 6 - 8 channels**

It is thus possible to configure «à la carte» the vision system.

## TECHNICAL FEATURES

<b>MODEL</b>	<b>6SXZ - 63 (fall)</b>
<b>Dimensions</b>	Width 804 / Depth 1512 / Height 1950
<b>Weight</b>	490kg
<b>Output</b>	Kernels = 400kg/hour
<b>Electricity</b>	220VAC - 1kW
<b>Compressed air</b>	Consumption: 500l/min 30m <sup>3</sup> /h Pressure : 7bar mini Volume : 150l (Maximum Distance of the compressor = 50m) Air dryer recommended
<b>Options</b>	Pallet Chassis / Extension legs / Air compressed alarm

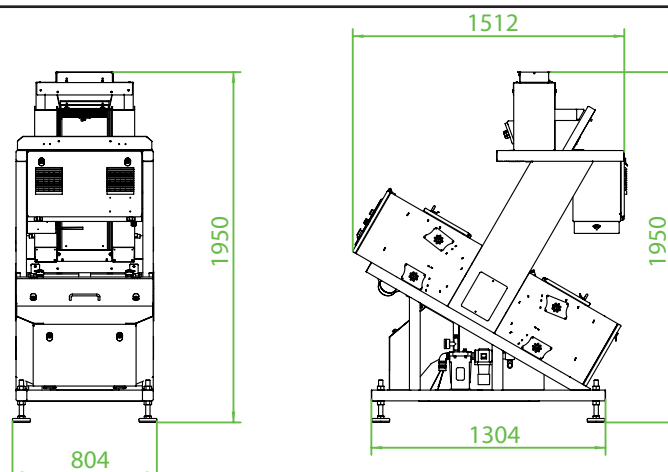

**MODEL 6SXZ-63**