

OPTICAL SORTER **6SXL**

THE REAL SORTING SOLUTION

Fresh Walnuts
Dry Walnuts
Kernels
Almonds
Hazelnuts
Chestnuts
Olives
Cherry
etc....

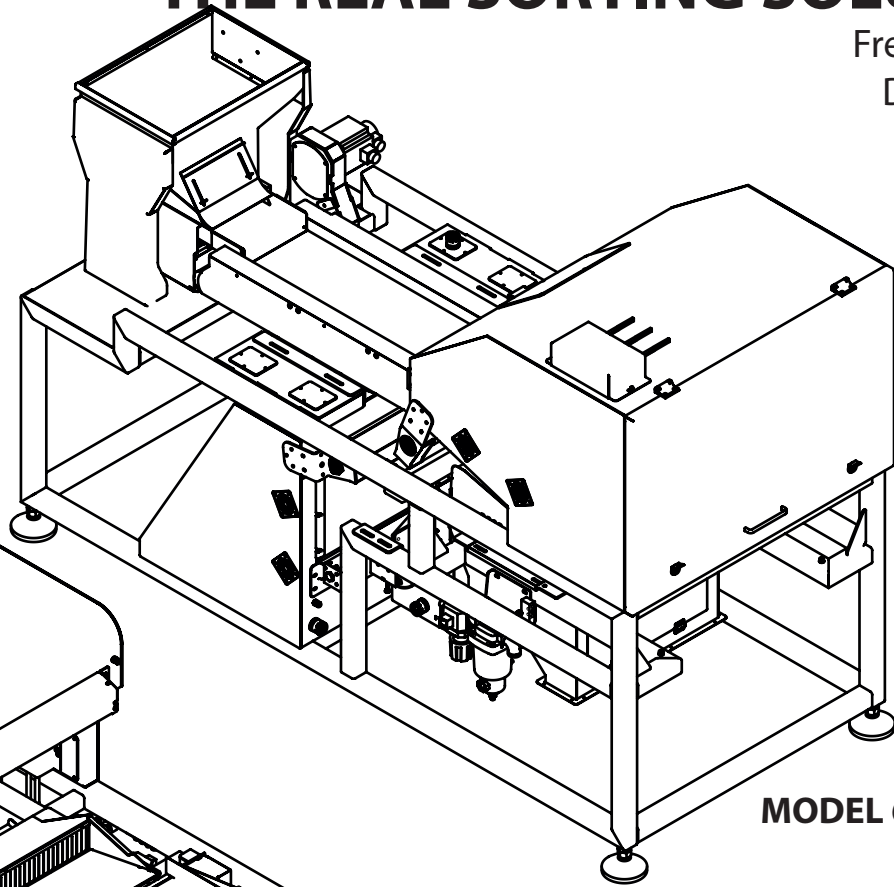

MODEL 6SXL-300

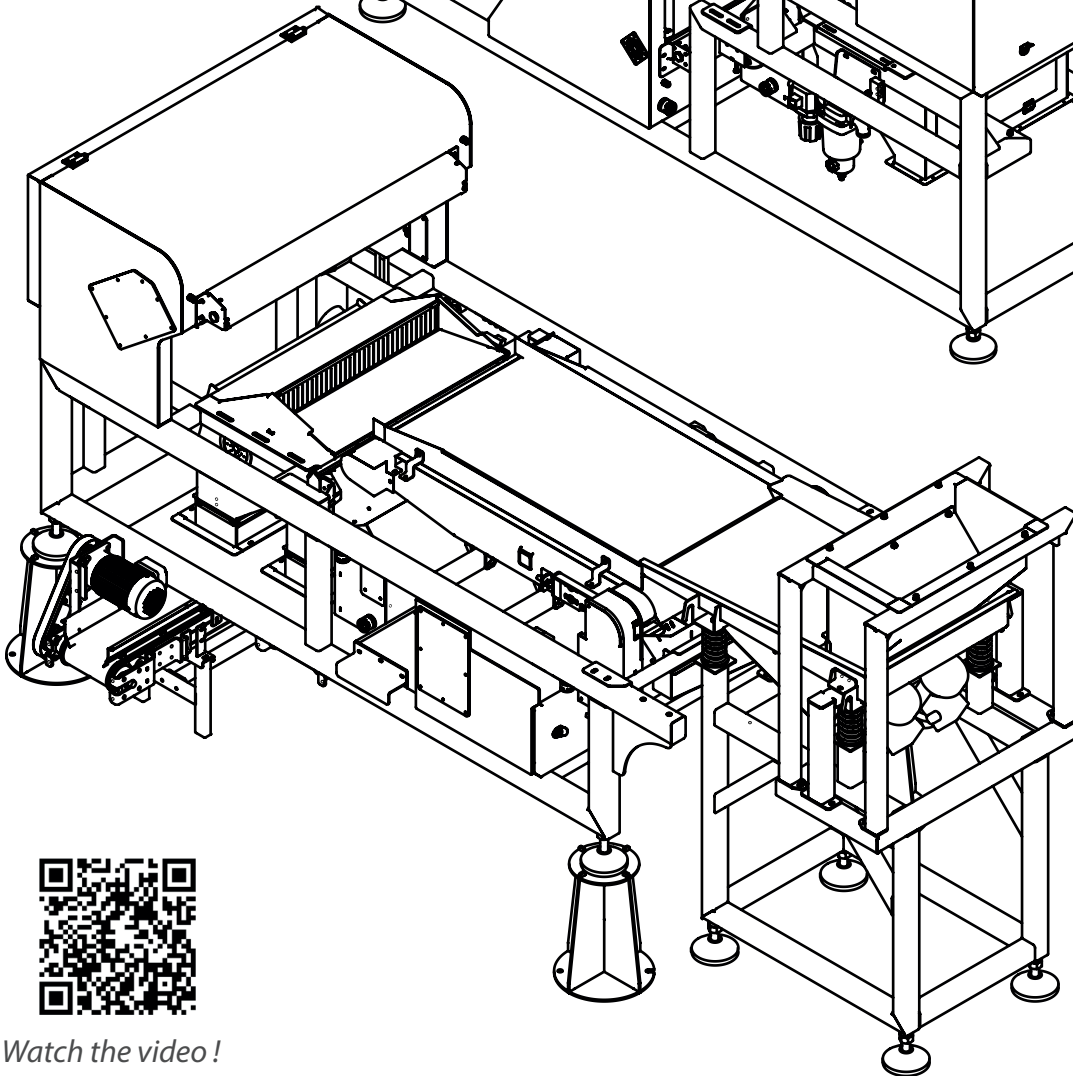

MODEL 6SXL-600



Watch the video!

Manufacturer of solutions for the harvest and work of the fruits 

A M B R o u s s e t
impasse du Tilleul
38470 BEAULIEU - France











Tél : +33 (0) 4 76 36 73 73
Fax : +33 (0) 4 76 36 70 82
E-mail : export@ambrousset.com
www.amb-rousset.com

OPTICAL SORTER GSXL

The sorter GSX adapts to any situations

In the nucicultural world it allows to sort in an efficient way the following products :

	FRESH WALNUTS	DRY WALNUTS	KERNELS	
ACCEPTED			 	
REJECTED	 		SHELLS MEMBRANES 	COLORS 

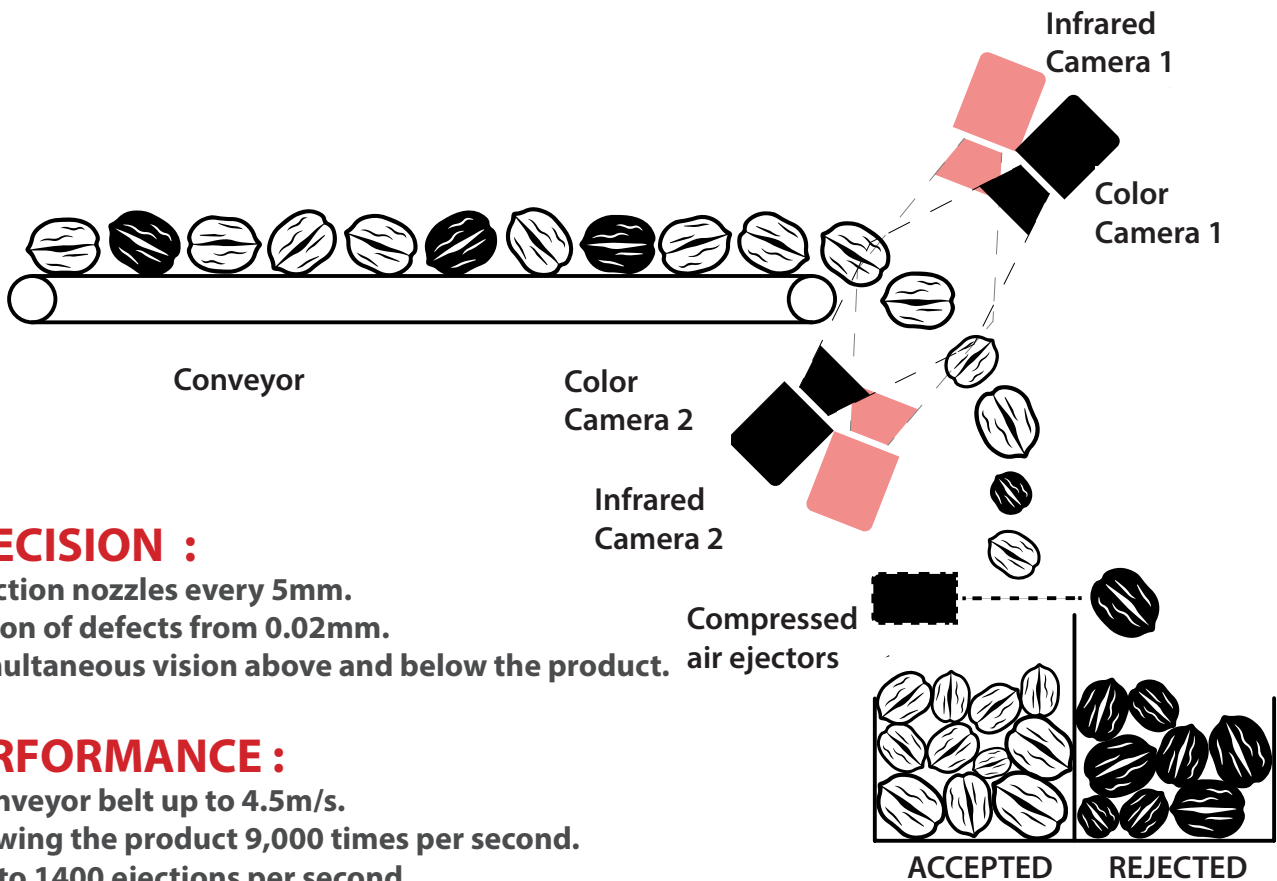

PRECISION :

- Ejection nozzles every 5mm.
- Vision of defects from 0.02mm.
- Simultaneous vision above and below the product.

PERFORMANCE :

- Conveyor belt up to 4.5m/s.
- Viewing the product 9,000 times per second.
- Up to 1400 ejections per second.

INTERFACE

- Touch screen IP6X
- User-friendly Interface
- Change settings in real time
- Fast and easy understand
- French/English/Italian/Spanish
- Saving settings in batches (recipes)

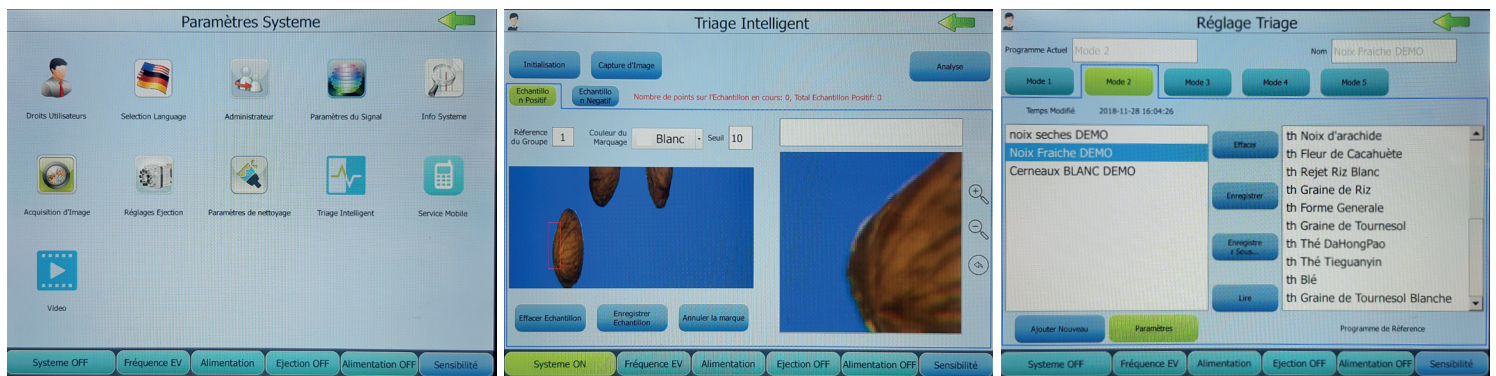

RELIABILITY

- LED lighting is guaranteed for 100,000 hours.
- Industrial solenoid valves guaranteed for 5 000 000 000 cycles.
- Industrial cameras perfectly protected from dust and humidity.
- Few mechanical parts.
- Fast diagnosis in case of failure.
- Remote maintenance.
- Ejection nozzles 100% removable.
- Automatic camera and carpet cleaning.
- Machine in IP6X therefore clean with clear water or compressed air (blower)



INTEGRATION

- Single feeding hopper on a vibrating channel.
- Food grade belt and 100% stainless steel chassis
- Configurable product discharge belt (right or left) included.
- Specific reception chute (option).
- Set-up on wheels or pallet chassis to be movable (Optional)
- 100% remote controllable. By local network wifi or ethernet



OPTICAL SORTER **6SXL**

CONFIGURATIONS:

- Depending on the product(s) to be sorted and the defects to be removed, different camera configurations are available :

COLOR CAMERAS : Advanced technology that offers the best sorting quality.

(E.g. Dry walnut/fresh/kernels, without the management of broken nuts and/or shells/membranes)

INFRARED CAMERAS : Advanced technology to bring out certain materials to better eject them (e.g. pebbles, wood, shells, metal, etc...).

These cameras are essential if you want a perfect result on products very complicated to sort. (Ex: Kernels with shell/membrane, broken dry nuts, stones in fresh nuts, etc...).

There are 3 belt widths to fit your work flow :

300mm (1 channel) - 600mm (2 channels) - 1200mm (4 channels)

It is thus possible to configure «à la carte» the vision system.

TECHNICAL FEATURES

MODEL	6SXL - 300	6SXL - 600	6SXL - 1200
Dimensions	Width 1150 Length 2670 Height 1860	Width 1150 Length 3500 Height 1860	Width 1750 Length 3500 Height 1860
Weight	750kg	950kg	1200kg
Output	Fresh walnuts = 2000kg/h Dry Walnut = 1500kg/h Kernels = 400kg/h	Fresh walnuts = 4000kg/h Dry walnuts = 3000kg/h Kernels = 800kg/h	Fresh walnuts = 8000kg/h Dry walnuts = 6000kg/h Kernels = 1600kg/h
Electricity	220VAC - 0.75kW 380 VAC - 1kW	220VAC - 0.75kW 380 VAC - 1kW	220VAC - 1kW 380 VAC - 1kW
Compressed Air	Consumption: 500l/min 30m ³ /h Network : 7bar mini Volume : 150l (Distance Max compressor= 50m)	Consumption: 1000l/min 60m ³ /h Network : 7bar mini Volume: 300l (Distance Max compressor = 50m)	Consumption: 2000l/min 120m ³ /h Network : 7bar mini Volume: 600l (Distance Max compressor = 50m)
Options	Pallet chassis / Extension legs / Compressed air Alarm / Double ejection		