

VIBRATING SIZING SIEVE FOR WALNUT KERNELS

C80



Manufacturer of solutions for the harvest and work of the fruits



AMB Rousset
impasse du Tilleul
38470 BEAULIEU - France



Tél : +33 (0) 4 76 36 73 73
Fax : +33 (0) 4 76 36 70 82
E-mail : export@ambrousset.com
www.amb-rousset.com

VIBRATING SIZING SIEVE FOR WALNUT KERNELS



Technical specifications

Electric vibrator driving (0,34 kW)

OPERATION

Continuous

ADVANTAGES

3 calibers (walnut standard : 1 oblong grid \emptyset 12/40 mm and 2 round grids \emptyset 13 mm and \emptyset 18 mm + one replacement oblong grid \emptyset 14/40 mm)

- Calibration area : 250 x 550 mm under the strip for a good strip centring

WEIGHT AND DIMENSIONS

Length : 1,70 m

Width : 0,68 m

Height : 0,74 m

Weight : 220 kg

Flow : from 70 up to 100 kg/hour

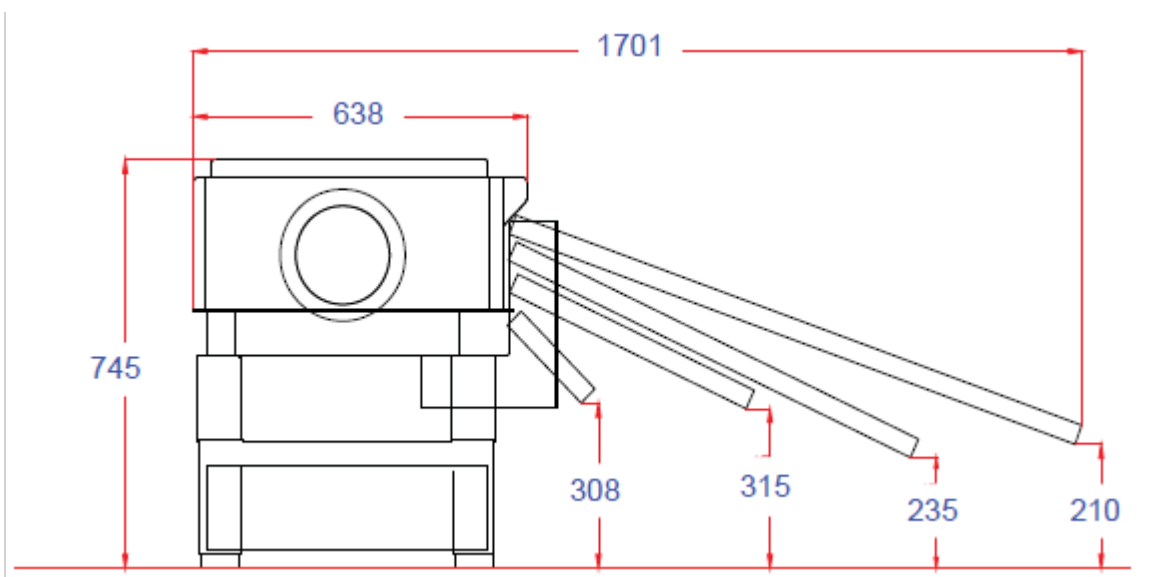

VIBRATING SIZING SIEVE FOR WALNUT KERNELS

C80

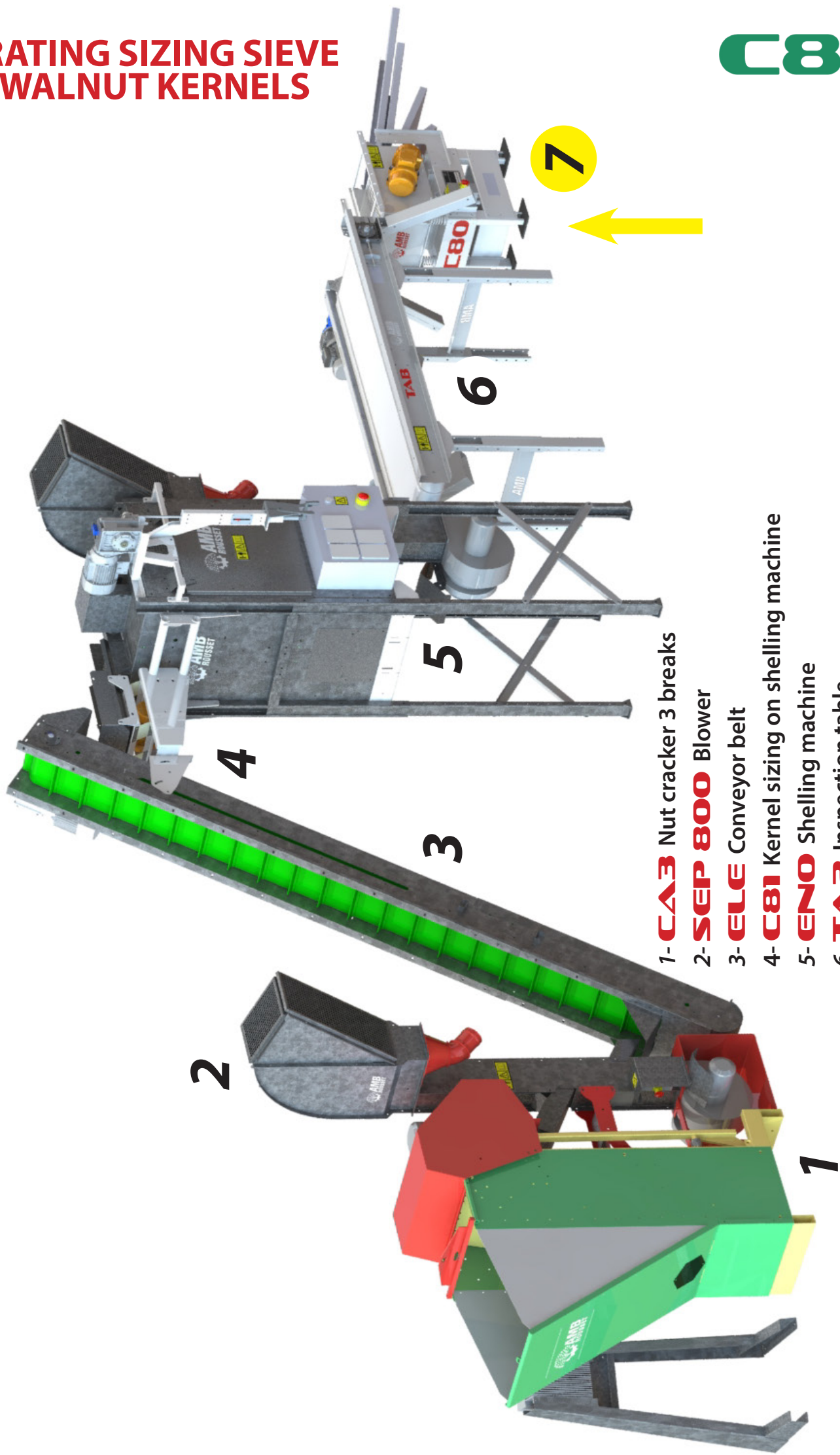

- 1- **CA3** Nut cracker 3 breaks
- 2- **SEP 800** Blower
- 3- **ELE** Conveyor belt
- 4- **C81** Kernel sizing on shelling machine
- 5- **ENO** Shelling machine
- 6- **TA2** Inspection table
- 7- **C80** Vibrating sizing sieve for kernels