

BLOWER SEP₈₀₀



Fruits and empty shells



BEFORE

Fruits

Empty shells



AFTER

Manufacturer of solutions for the harvest and work of the fruits



AMB Rousset
impasse du Tilleul
38470 BEAULIEU - France



Tél : +33 (0) 4 76 36 73 73
Fax : +33 (0) 4 76 36 70 82
E-mail : export@ambrousset.com
www.amb-rousset.com

Main features

Technical specifications

Motor	Three phase electric motor (380 V) directly connected on the blower
Frame	Galvanized steel folded sheet
Fonctionnement	This device separates the broken shells (after breaking) by ventilation
	Adjustable air flow by diaphragm
Advantages	Low noise level (72,1 db/a)
Weight and dimensions	Length : 0,87 m Width : 0,64 m Height : 2,36 m Weight : 80 kg Flow : 50 to 200 kg/hour

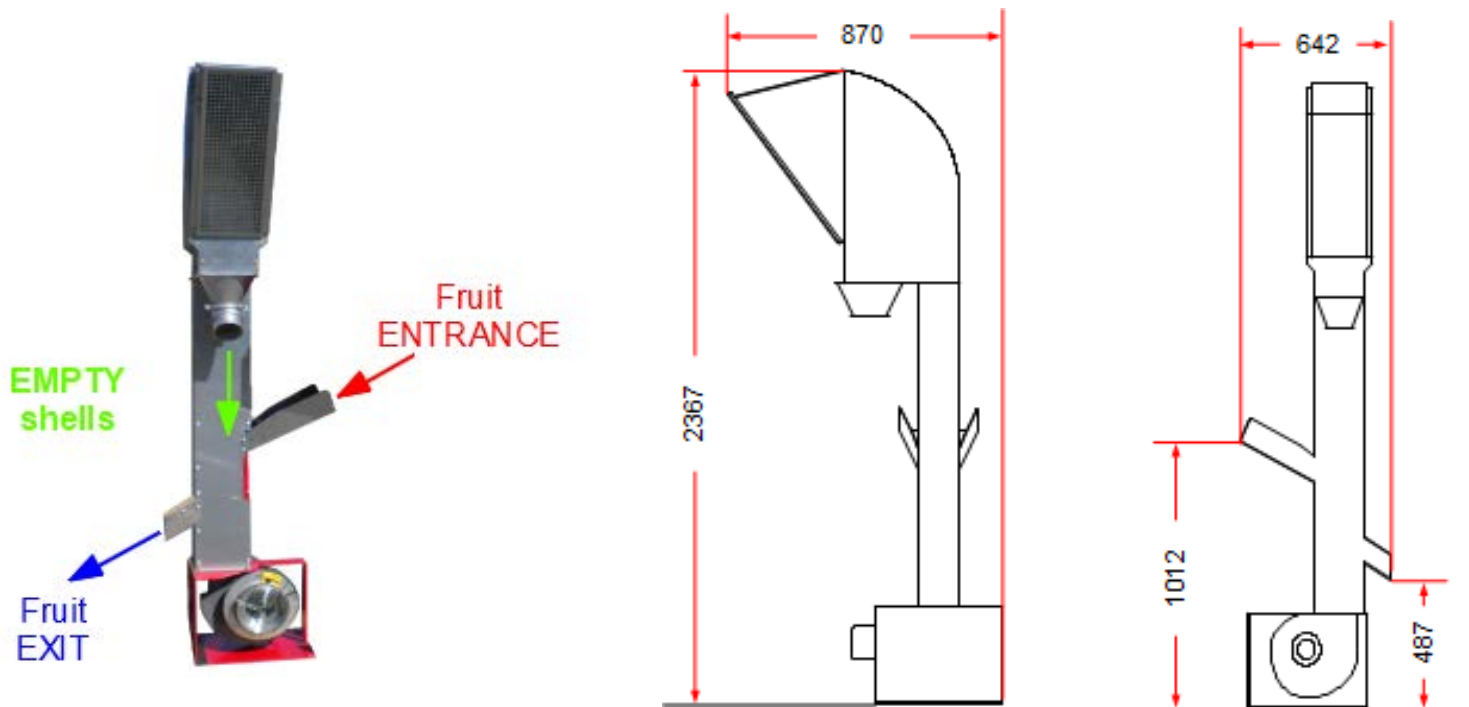

OPTION SEP0027 : KIT GUIDAGE DÉCHETS SOUFFLERIE

